

146

(1) If  $(146)_x + (313)_{x-2} = (246)_8$ , then the value of base  $x$  is:

- a. 5      b. 6      c. 7      d. 9

(2) The truth table for implementing a boolean variable  $F$  is given by

C	B	A	F
0	0	0	d
0	0	1	1
0	1	0	1
0	1	1	d
1	0	0	0
1	0	1	0
1	1	0	0
1	1	1	1

where  $d$  represents don't care states. The minimized expression for  $F$  is

- a.  $B\bar{C} + A\bar{C} + AB$   
 b.  $A\bar{B} + \bar{C}$   
 c.  $\bar{A}B\bar{C} + A\bar{B}\bar{C} + ABC$   
 d. None of above

(3) The state transition diagram for a sequence generator is shown in figure

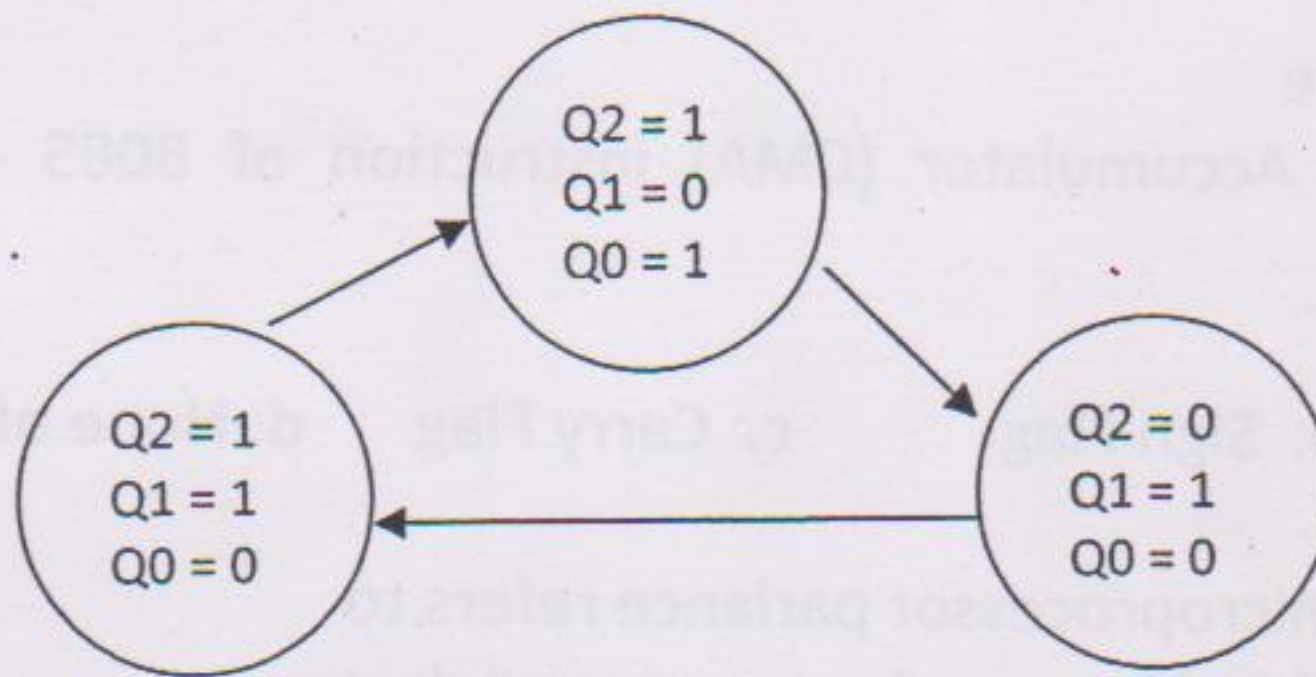

It is designed using D F/Fs and combinational logic blocks  $L_1$ ,  $L_2$  &  $L_3$  and is initialized at  $(Q_2=1, Q_1=0, Q_0=1)$

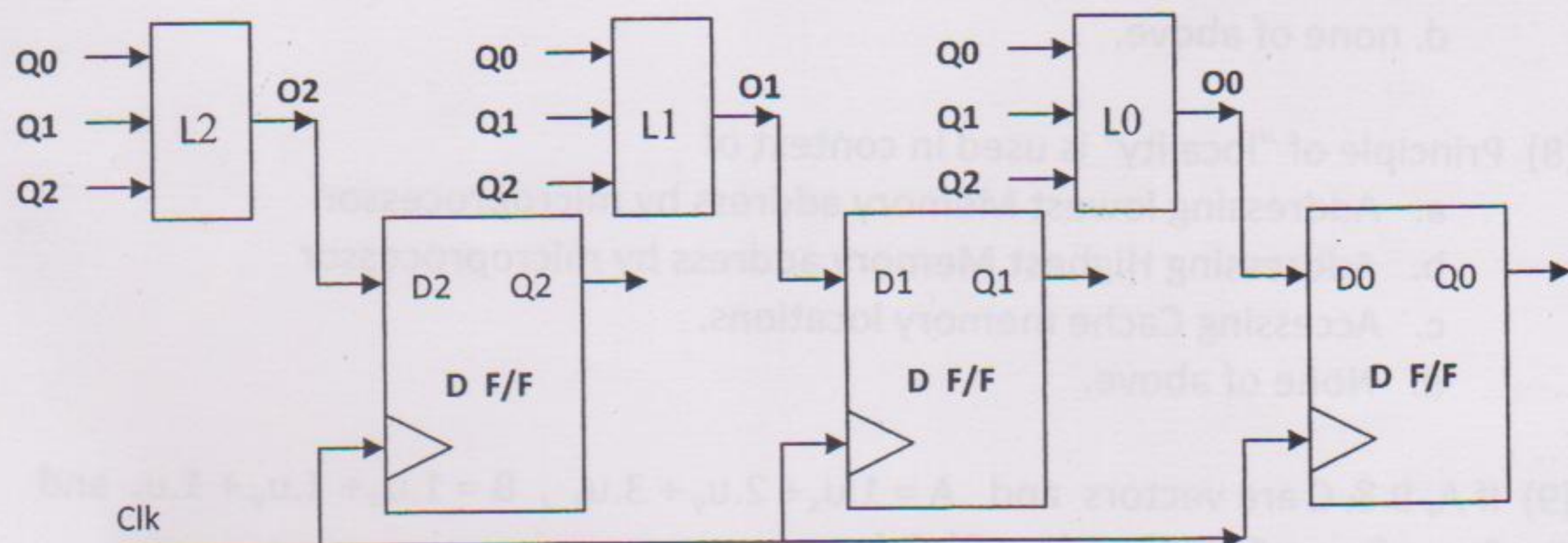



The minimized expressions for  $O_0$ ,  $O_1$  &  $O_2$  are :

a.  $O_2 = Q_2$        $O_1 = Q_1$        $O_0 = Q_0$

b.  $O_2 = Q_1 \cdot \bar{Q}_0$        $O_1 = \bar{Q}_0 \cdot Q_1 \cdot \bar{Q}_2 + Q_0 \cdot \bar{Q}_1 \cdot Q_2$        $O_0 = \bar{Q}_0 \cdot Q_1 \cdot Q_2$

c.  $O_2 = Q_1$        $O_1 = Q_0 + \bar{Q}_2$        $O_0 = Q_1 \cdot Q_2$

d. None of above

(4) The number of comparators needed in a 8-bit flash type A to D converter is

- a. 8      b. 16      c. 255      d. 256

(5) The register in the 8085A that is used to keep track of the memory address of the next op-code to be run in the program is the :

- a. stack pointer  
b. program counter  
c. accumulator  
d. None of above

(6) The Complement Accumulator (CMA) instruction of 8085 processor on execution affects

- a. Zero Flag      b. Sign Flag      c. Carry Flag      d. None of the flags

(7) "Cycle Stealing" in microprocessor parlance refers to

- a. Special type of DMA access by an external device  
b. RESET operation at power ON by microprocessor  
c. Interrupt Acknowledge cycle  
d. none of above.

(8) Principle of "locality" is used in context of

- a. Addressing lowest Memory address by microprocessor  
b. Addressing Highest Memory address by microprocessor  
c. Accessing Cache memory locations.  
d. None of above.

(9) If A, B & C are vectors and  $A = 1.u_x + 2.u_y + 3.u_z$ ,  $B = 1.u_x + 1.u_y + 1.u_z$  and  $C = 3.u_x + 2.u_y + 1.u_z$ , then  $(A \times B) \cdot C$  is :

- a. 2      b. 1      c. 0      d. -1





(10) The system of equations  $x + y + z = 6$ ,  $2x + y + z = 7$ ,  $x + 2y + z = 8$  has

- a. A unique solution
- b. No solution
- c. An infinite number of solutions
- d. None of these

(11) If  $x = e^{y+e^{y+e^{y+\dots}}}$

then  $\frac{dy}{dx}$  is

- a.  $(1-x)$
- b.  $(1-x)/x$
- c.  $1/x$
- d.  $x/(1-x)$

(12) The area bounded by the curves  $y^2 = x$ ,  $y = x$  is given by

- a.  $2/3$
- b.  $1/2$
- c.  $1/6$
- d.  $1/3$

(13) The eigen values of the matrix are

$$\begin{bmatrix} \cos \alpha & \sin \alpha \\ \sin \alpha & \cos \alpha \end{bmatrix}$$

- a.  $\pm \cos \alpha$
- b.  $\pm \sin \alpha$
- c.  $\tan \alpha$  &  $\cot \alpha$
- d.  $\cos \alpha \pm \sin \alpha$

(14) The Laplace Transform of  $x(t)$  formed by convolution operator is :

$$x(t) = \{t.u(t)\} \otimes \{\cos 2\pi t.u(t)\}$$

- a.  $1/[s(s^2 + 4\pi^2)]$
- b.  $2\pi/[s(s^2 + 4\pi^2)]$
- c.  $1/[s^2(s^2 + 4\pi^2)]$
- d.  $s^3/(s^2 + 4\pi^2)$

(15) A random variable  $X$  has  $\bar{X} = 0$  &  $\sigma_X^2 = 1$ . Form a new random variable  $Y = 2X + 1$ . The values of  $\bar{Y}$  &  $\sigma_Y^2$  are :

- a.  $0$  &  $1$
- b.  $1$  &  $2$
- c.  $1$  &  $4$
- d. None of these





(16) Person X can solve 80% of the ISRO question paper and Person Y can solve 60%. The probability that at least one of them will solve a problem from the question paper, selected at random is :

- a. 0.48      b. 0.70      c. 0.88      d. 0.92

(17)  $1 \text{ cm}^3$  of pure Germanium at  $20^\circ\text{C}$  contains about  $4.2 \times 10^{22}$  atoms,  $2.5 \times 10^{13}$  free electrons and  $2.5 \times 10^{13}$  holes. 0.001% of Arsenic doping donates an extra  $10^{17}$  free electrons in the same volume. The approximate number of holes in one  $\text{cm}^3$  in the doped semiconductor under equilibrium condition is :

- a.  $6.25 \times 10^9$       b.  $2.5 \times 10^9$       c.  $10.5 \times 10^9$       d.  $10^{17}$

(18) Measurement of Hall coefficient enables the determination of :

- a. Temperature coefficient and thermal conductivity  
b. Mobility and concentration of charge carriers  
c. Fermi level and forbidden energy gap  
d. None of the above

(19) Silicon is not suitable for fabrication of light emitting diodes because it is :

- a. An indirect band gap semiconductor  
b. A direct band gap semiconductor  
c. A wide band gap semiconductor  
d. A narrow band gap semiconductor

(20) The band gap of elements arranged in ascending order is :

- a. Diamond, Ge, Si  
b. Si, Ge, Diamond  
c. Ge, Si, Diamond  
d. Diamond, Si, Ge

(21) The following statements are made for NMOS & PMOS

1. The carrier mobility in NMOS is higher ✓
2. PMOS require less area than NMOS ✗
3. NMOS circuits are smaller than PMOS ✗
4. PMOS are faster in switching. ✗



Of these, the true statements are :

- a. 2 and 4 only
- b. 2 and 3 only
- ✓ c. 1 and 3 only
- d. 1, 2 and 3 only

(22) The following statements are made for FETs

1. In n-channel depletion mode MOS in the active region, the control voltage  $V_{GS}$  is negative. ✓
2. NMOS in depletion mode is cut off for  $V_{GS}=0$  ✓
3. NMOS in enhance mode is cut off for  $V_{GS}=0$  ✓
4. There is no path between source and drain in the enhancement mode ✓

Of these, the true statements are :

- a. 1 and 2 only
- b. 1 and 3 only
- c. 3 and 4 only
- d. 1, 3 and 4 only

(23) Special handling precautions should be taken when working with MOS devices. The statement which is not true is :

- a. All test equipment should be grounded. ✓
- ✓ b. MOS devices should have their all leads shorted together during shipment and storage. ✗
- c. Never remove or insert MOS devices with the power on. ✓
- d. MOS devices do not require grounding straps used for CMOS. ✓

(24) If the input to the circuit of Figure is a sine wave, then the output will be :

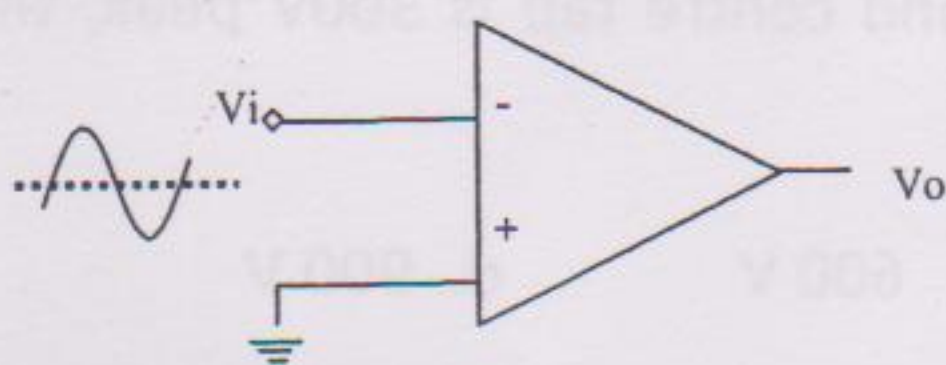

- a. Half wave rectified sine wave
- ✓ b. A full wave rectified sine wave
- c. A square wave
- d. A triangular wave



- (25) A high gain OpAmp has  $R_f=10^5 \Omega$  &  $R_i=10^3 \Omega$ . The correct statement is :
- The non-inverting gain & inverting gain are nearly same.
  - The inverting gain is very much higher than non-inverting gain
  - The non-inverting gain is very much higher than inverting gain
  - The inverting & non-inverting gains are unrelated
- (26) For various types of oscillators, the correct statement is :
- LC oscillators are more stable than crystal oscillators
  - Crystal oscillators have highest Q
  - Phase-shift oscillators have the widest range of frequency
  - Wien bridge oscillator is used where a single frequency oscillator is required
- (27) For Butterworth & Chebyshev filters, the correct statement is :
- Butterworth response has a sharp cut-off
  - Chebyshev response has a flat response in the pass band
  - Butterworth response has ripples in the pass band
  - Chebyshev response has ripples in the pass band
- (28) In a feedback series regulator circuit, the output voltage is regulated by controlling the
- Magnitude of the I/P voltage
  - Gain of the feedback transistor
  - Voltage drop across the series pass transistor
  - Reference voltage
- (29) In a fullwave rectifier circuit with centre tap transformer, if voltage between one end of secondary winding and centre tap is 300V peak, then PIV (peak inverse voltage) is
- 300 V
  - 150 V
  - 600 V
  - 900 V
- (30) The rms value of the periodic waveform as shown in Figure is

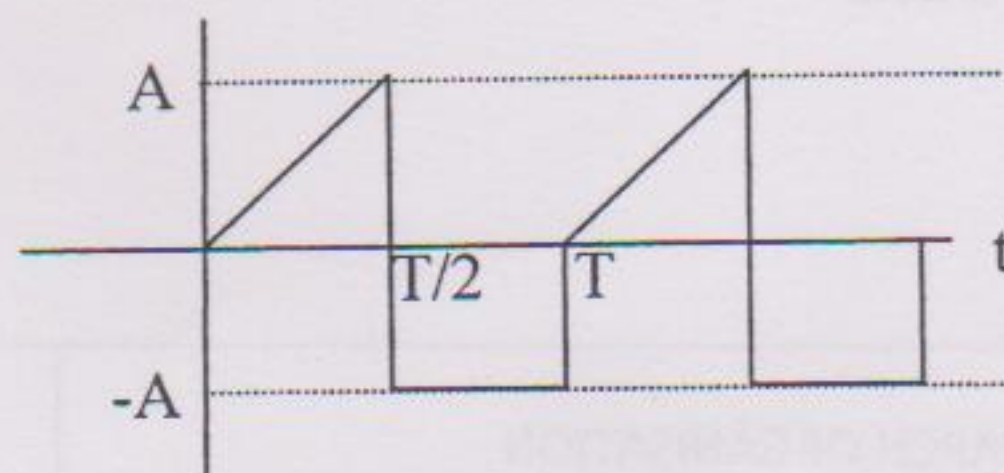

- $\sqrt{3/2} A$
- $\sqrt{2/3} A$
- $\sqrt{1/3} A$
- $\sqrt{2} A$







(34) In this circuit,  $V$  is a sinusoid input with freq  $f$ , current  $i$  contains :

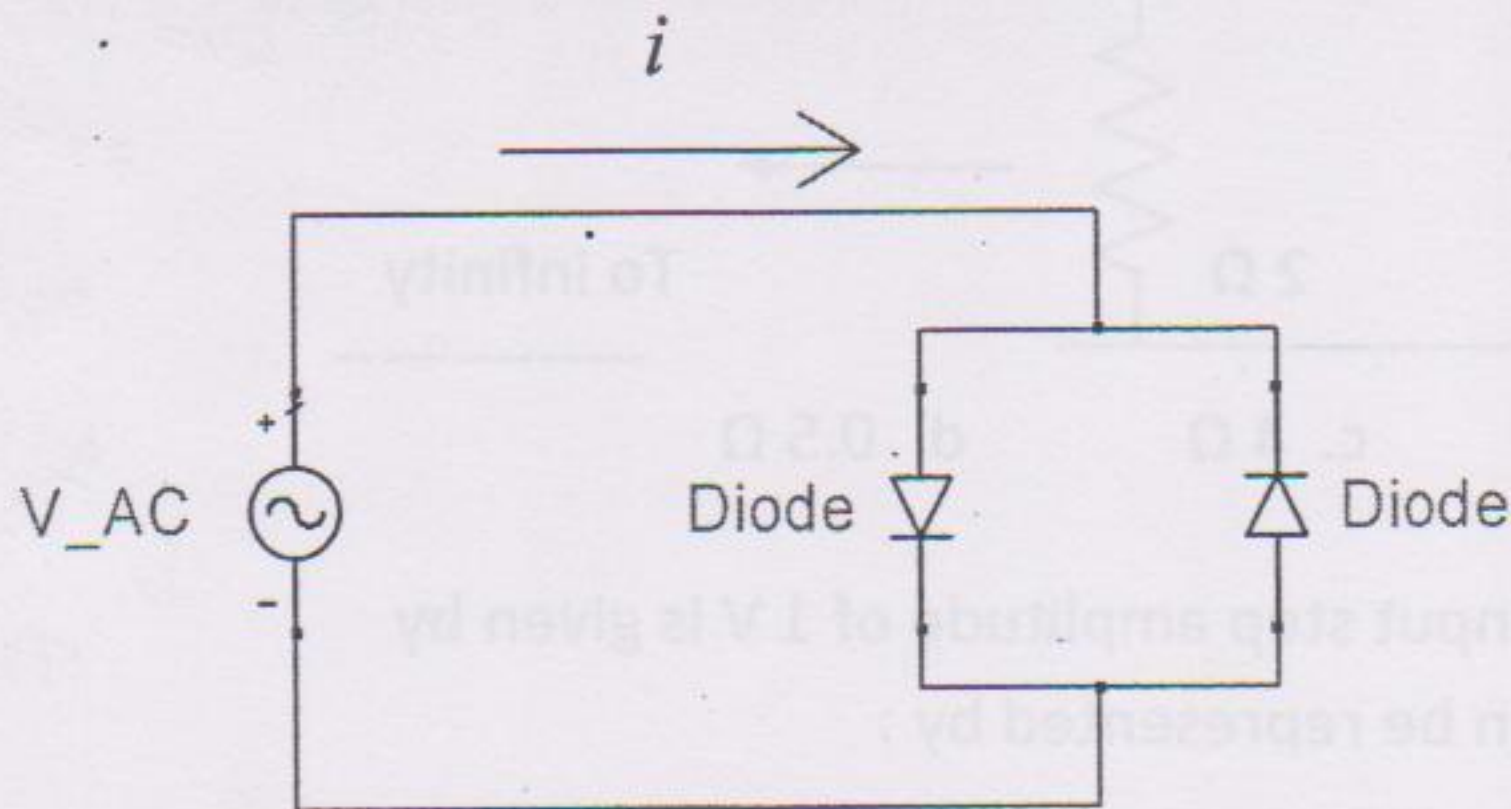

- Only  $f$
- All harmonics of  $f$
- Only even harmonics of  $f$
- Only odd harmonics of  $f$

(35) The effect of phase error of local oscillator on spectral components in coherent detection of SSB Amplitude modulated signal is :

- The frequency of demodulated signals varies with fixed amplitude
- Amplitude of demodulated signals varies with fixed frequency
- Both amplitude & frequency vary
- The recovered signal has phase offset with fixed amplitude

(36) The maximum transmission power efficiency of DSB-C Amplitude modulation is :

- 25%
- 33.33%
- 50%
- 100%

(37) For identical total transmitted power, the ratio of S/N for wide band FM to S/N of DSB-AM (with  $m_a=1$ ) is :

( Given  $f_m = 15$  KHz & frequency deviation  $= \pm 75$  KHz)

- 112.5
- 300
- 75
- 450



(38) A signal  $m(t) = 3\cos(6000\pi t) + 4\cos(7000\pi t) + 5\cos(10000\pi t)$  to be sampled. What is the minimum sampling rate for band pass sampling for truth full representation :

- a. 2000 Hz
- b. 3000 Hz
- c. 5000 Hz
- d. 10000 Hz

(39) Minimum number of bits required to represent maximum value of given analogue signal with 0.1% accuracy is:

- a. 8 bits
- b. 9 bits
- c. 10 bits
- d. 12 bits

(40) An Ideal power limited communication channel with additive white Gaussian noise is having 4 KHz band width and Signal to Noise ratio of 255. The channel capacity is:

- a. 8 kilo bits /sec
- b. 9.63 kilo bits / Sec
- c. 16 kilo bits / Sec
- d. 32 kilo bits / Sec

(41) An Ideal power limited communication channel with additive white Gaussian noise with 1 MHz band width and Signal to Noise ratio of 15 is transmitting the information at theoretical maximum rate. If the Signal to Noise ratio is reduced to 7, how much bandwidth is required to maintain same rate:

- a. 15/7 MHz
- b. 4/3 MHz
- c. 2 MHz
- d. None of these





(42) Following constellation diagram represents:

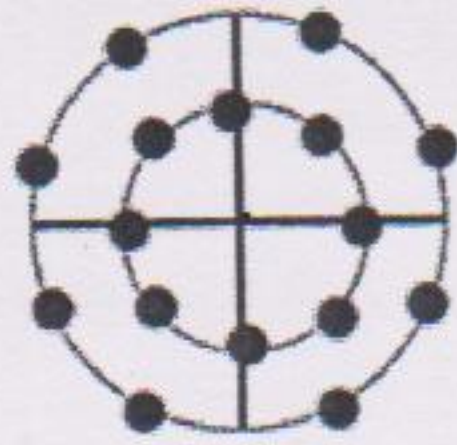

- a. 16 PSK
- b. 16 QAM
- c. 16 APSK
- d. All of above

(43) The information rate to be transmitted is 900 bits /sec, FEC is  $\frac{3}{4}$ , the symbol rate for QPSK modulation scheme is :

- a. 225 symbols /sec
- b. 450 symbols /sec
- c. 600 symbols /sec
- d. 675 symbols /sec

(44) Electric displacement density  $D$  at any point on spherical surface of radius  $R$  with a charge  $Q$  at the centre in a medium with dielectric constant  $\epsilon$  is:

- a.  $Q/(4\pi \epsilon R^2)$
- b.  $Q/(4\pi R^2)$
- c.  $(Q/4\pi \epsilon R)^2$
- d.  $Q/(4\pi R)^2$

(45) Which of the following does not represent Maxwell's Equation:

a.  $\oint E \cdot ds = - \int \frac{\partial B}{\partial t} \cdot da$

b.  $\oint D \cdot da = \int \rho \cdot dV$

c.  $\nabla \times H = B + J$

d.  $\oint B \cdot da = 0$



(46) For a homogeneous and isotropic medium with a charge density  $\rho$  & dielectric constant  $\epsilon$ , the Poisson's equation for electrical potential  $V$  is :

a.  $\nabla^2 V = \frac{\rho}{\epsilon}$

b.  $\nabla^2 V = -\frac{\rho}{\epsilon}$

c.  $\nabla \cdot V = \frac{\rho}{\epsilon}$

d.  $\nabla \cdot V = -\frac{\rho}{\epsilon}$

(47) For a plane travelling EM wave, the correct equation for characteristic impedance  $Z$  for the medium with permittivity of  $\epsilon$  and permeability of  $\mu$  is :

a.  $Z = \sqrt{\frac{\mu}{\epsilon}}$

b.  $Z = \sqrt{\frac{\epsilon}{\mu}}$

c.  $Z = \sqrt{(\mu * \epsilon)}$

d.  $Z = \frac{1}{\sqrt{\mu * \epsilon}}$

(48) A plane wave propagating in the dielectric medium has an electric field given as  $E_x = E_0 \cos(2.6 \times 10^{10} t - 100z)$ . The phase velocity of plane wave is :

a.  $10^6$  m/sec

b.  $2.6 \times 10^8$  m/sec

c.  $3.0 \times 10^8$  m/sec

d.  $4.0 \times 10^8$  m/sec

(49) A plane wave propagating in the dielectric medium has an electric field given as  $E_x = E_0 \cos(3 \times 10^{10} t - 100z)$ . The dielectric constant of the medium is :

a. 1.33

b. 1.00

c. 1.01

d. 2.15





(50) A transmission line of  $50 \Omega$  characteristic impedance terminated by a load impedance of  $50-j50$ . The magnitude of reflection coefficient at the load is :

- a.  $\sqrt{5}/3$
- b.  $\sqrt{3}/5$
- c.  $3\sqrt{5}$
- d. None of above

(51) The outer conductor diameter and the inner conductor diameter dimensions of a coaxial cable are made twice to its original value. (Coaxial line is filled with dielectric material having dielectric constant  $\epsilon_r = 4.0$ ). The correct statement is :

- a. Impedance remain same to it's original value
- b. Impedance reduces to half of it's original value
- c. Impedance increase & becomes twice of original value
- d. None of above

(52) A non dispersive media has :

- a) Group velocity > phase velocity
- b) Group velocity < phase velocity
- c) Group velocity = phase velocity
- d) None of above

(53) A plane wave is characterized by :

$$\vec{E} = (0.5 \hat{x} + \hat{y} e^{j\pi/2}) e^{j\omega t - jkz}$$

The wave is

- a. Linearly Polarized
- b. Circularly Polarized
- c. Unpolarized
- d. Elliptically Polarized

(54) If a right hand circularly polarised wave is incident on a perfect conductor.

The reflected wave is :

- a. Right circularly polarised wave
- b. Left circularly polarised wave
- c. Linear polarised wave
- d. None of above



(55) In which of the following cases the divergence of electric field is zero

a. When electric field flows uniform through open tubes



b. When electric field is released from the tube

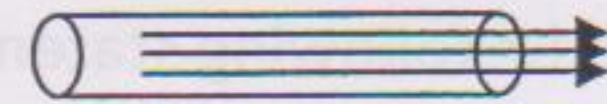

c. When electric field is within the closed tube

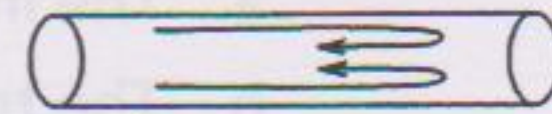

d. None of above

(56) Skin depth at 2 GHz for a gold conductor with  $\sigma = 4.55 \times 10^7$  S/m is  $1.5 \mu\text{m}$ .  
Skin depth ( in  $\mu\text{m}$  ) at 8 GHz & 18 GHz is :

a. 3.00, 4.50    b. 0.75, 0.50    c. 0.375, 0.055    d. 1.50, 1.00

(57) The S matrix of a lossless line having length  $\lambda/4$  is

a.  $\begin{bmatrix} 1 & 0 \\ 0 & 1 \end{bmatrix}$     b.  $\begin{bmatrix} 1 & -1 \\ -1 & 1 \end{bmatrix}$     c.  $\begin{bmatrix} 0 & j \\ j & 0 \end{bmatrix}$     d. None of Above

(58) In the following Smith Chart,

Constant VSWR  
circle

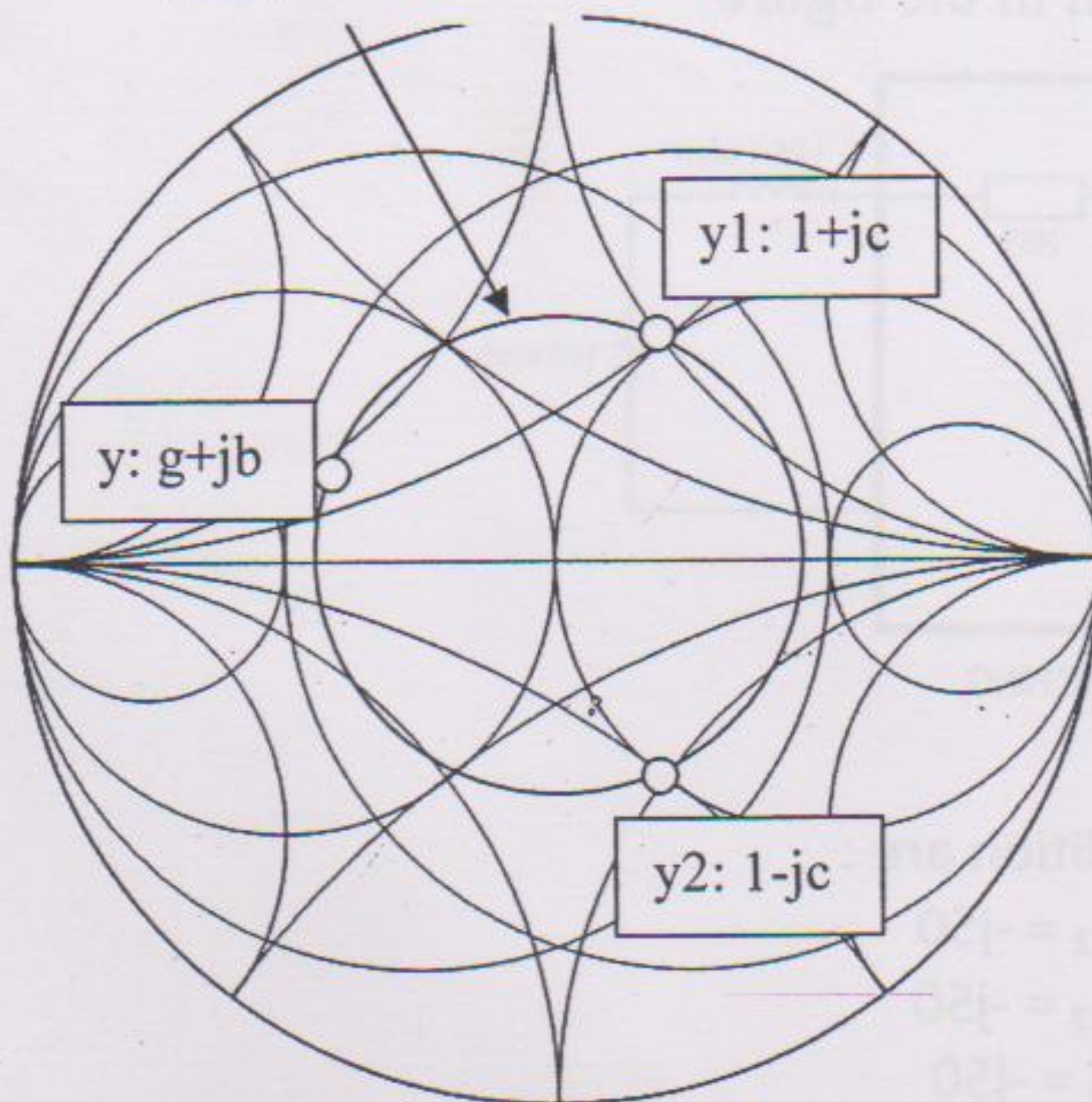

the movement from y along a constant VSWR circle to y1 needs addition of

- Capacitance in series with y
- Capacitance in shunt with y
- TRL in series with y
- Stub with y



(59) If the RF transmission is terminated in its Characteristic impedance  $Z_c$ , which of the following statements is wrong :

- The input impedance of transmission line becomes  $Z_c$ .
- The transmission line acts as an infinite long transmission line.
- The VSWR becomes one
- The VSWR becomes infinite.

(60) The loss-less , quarter wavelength long , RF transmission of characteristic impedance  $50 \Omega$  is terminated in pure resistive load impedance  $100 \Omega$ , the input impedance is :

- $5 \Omega$
- $10 \Omega$
- $25 \Omega$
- $500 \Omega$

(61) A lossless matching circuit is shown in the figure

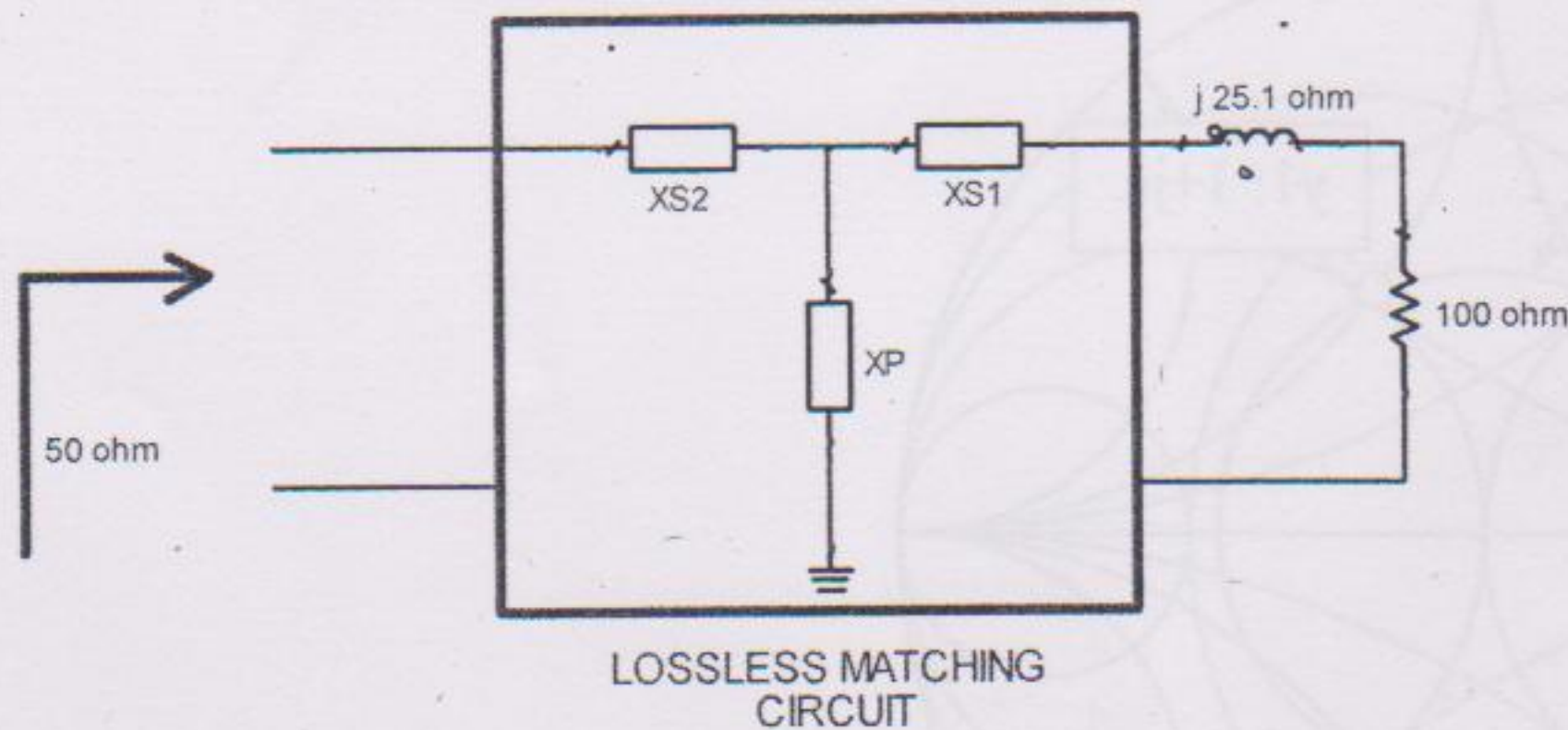

The values satisfying the matching condition are :

- $X_{S1} = -j25.1$  ,  $X_p = +j100$  ,  $X_{S2} = -j50$
- $X_{S1} = +j25.1$  ,  $X_p = -j100$  ,  $X_{S2} = -j50$
- $X_{S1} = -j25.1$  ,  $X_p = -j100$  ,  $X_{S2} = -j50$
- $X_{S1} = +j25.1$  ,  $X_p = +j100$  ,  $X_{S2} = +j100$

(62) The true statement for wave propagation in rectangular wave guides filled with air is:

- The phase velocity is equal to velocity of light in air
- The phase velocity is always more than the velocity of light in air
- The phase velocity is always less than the velocity of light in air
- The phase velocity is un-defined.



(63) As the wave frequency approaches to cut-off frequency of wave guide, the correct statement is :

- a. The phase velocity of waves tends to zero.
- b. The phase velocity of waves tends to velocity of light.
- c. The phase velocity of waves tends to infinite.
- d. None of these.

(64) The EM wave which does not propagate through a rectangular waveguide with  $a=30$  mm &  $b=15$  mm is :

- a. EM wave of frequency 4.5 GHz
- b. EM wave of frequency 5.5 GHz
- c. EM wave of frequency 50 GHz
- d. EM wave of frequency 300 GHz

(65) The minimum input signal that gives output signal to noise ratio of 10 dB in a system that has an input impedance equal to  $50 \Omega$ , a noise figure of 4 dB and bandwidth of 100 KHz is : [  $10 \cdot \log(KT_0) = -174$  dBm ]

- a.  $0.32 \mu\text{V}$
- b.  $1.41 \mu\text{V}$
- c.  $0.245 \mu\text{V}$
- d. None of the above

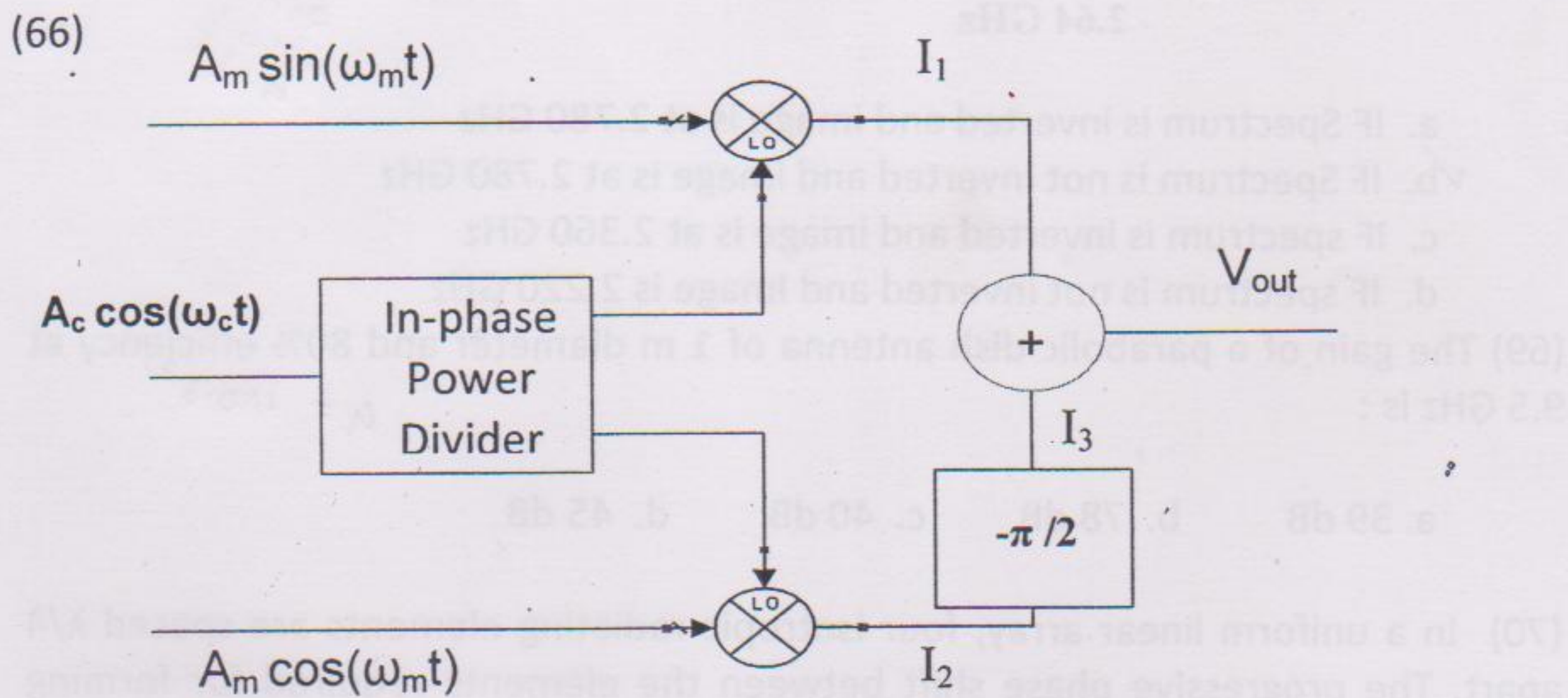

In this circuit,  $V_{out}$  is :

- a. Upper Sideband ( $\omega_L + \omega_m$ )
- b. Lower Sideband ( $\omega_L - \omega_m$ )
- c. Both Upper and Lower Sideband ( $\omega_L \pm \omega_m$ )
- d. None of above



(67) The RF amplifier A is having 3 dB NF & 5 dB of gain, amplifier B is having 3.5 dB NF & 15 dB . For overall noise figure of the cascaded system, the correct statement is :

- a. A as first stage & B as second stage offers minimum over all NF
- b. B as first stage & A as second stage minimum over all NF
- c. Both the combination will offer same overall NF
- d. Over all NF will be less than 3 dB.

(68) For this RF Circuit, the correct statement is :

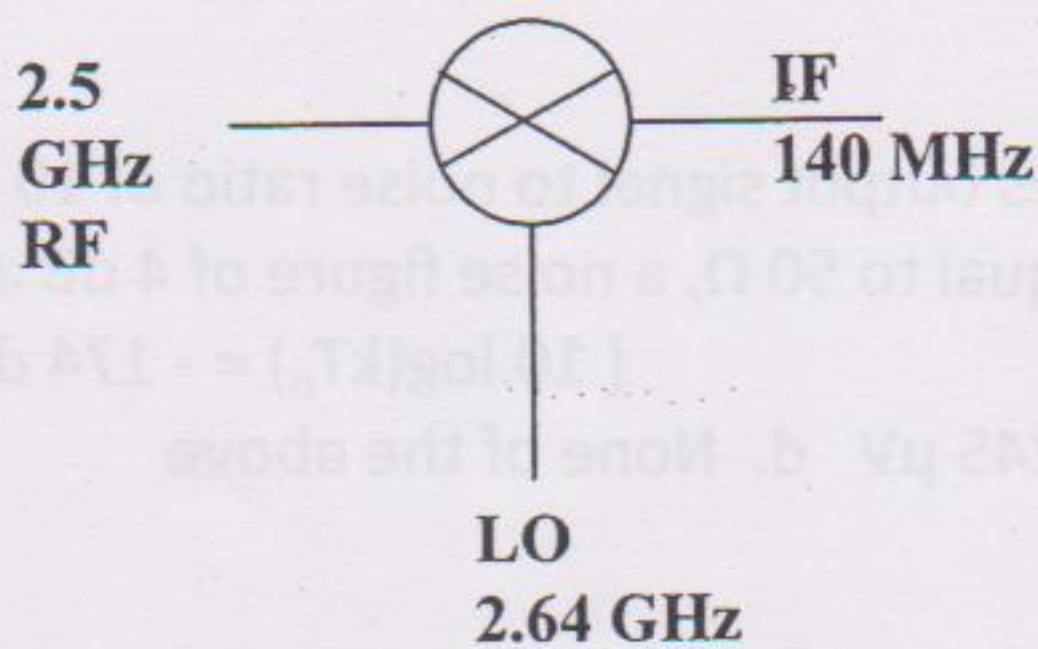

- a. IF Spectrum is inverted and image is at 2.780 GHz
- b. IF Spectrum is not inverted and image is at 2.780 GHz
- c. IF spectrum is inverted and image is at 2.360 GHz
- d. IF spectrum is not inverted and Image is 2.220 GHz

(69) The gain of a parabolic dish antenna of 1 m diameter and 80% efficiency at 9.5 GHz is :

- a. 39 dB
- b. 78 dB
- c. 40 dB
- d. 45 dB

(70) In a uniform linear array, four isotropic radiating elements are spaced  $\lambda/4$  apart. The progressive phase shift between the elements required for forming the main beam at  $60^\circ$  of the end fire is :

- a.  $-\pi$
- b.  $-\pi/2$
- c.  $-\pi/4$
- d.  $-\pi/8$

(71) The radiation resistance of a thin line centre fed  $\lambda/2$  antenna with sinusoid current distribution is :

- a.  $73 \Omega$
- b.  $73 + j42.5 \Omega$
- c.  $50 \Omega$
- d.  $75 \Omega$



(72) To increase gain of a parabolic reflector antenna by 6dBi, the correct statement is : ( Assuming efficiency 70%)

- a. Diameter is to be increased to 6 folds
- b. Diameter is to be increased to 4 folds
- c. Diameter is to be increased to 2 folds
- d. None of above

(73) The waveguide Magic Tee can be used as:

- a. An Isolator
- b. T/R switch in trans-receiver
- c. Adjustable Phase Shifter
- d. All of these

(74) The microwave device working on the principal of Faraday rotation is called as:

- a. Rotary joint
- b. Circulator
- c. Isolator
- d. None of these

(75) The phase difference between adjacent anode poles of Magnetron is generally:

- a. Zero radians
- b.  $\pi/4$  radians
- c.  $\pi/2$  radians
- d.  $\pi$  radians

(76) Which of the following devices cannot be used as microwave oscillator :

- a. IMPATT diode
- b. PN Junction diode
- c. TRPATT diode
- d. BARRITT diode





(77) For a Phase Locked Loop system, the open loop transfer function is

$$G(s) = \frac{1000}{s(s/1192 + 1)}$$

The phase margin is  $50^\circ$  and the crossover frequency is approximately 1000 rad/s. A time delay is introduced in the phase detector reducing the phase margin to  $40^\circ$ . The maximum permissible time delay ( in seconds) is :

- $10^{-4}$
- 0.174
- $1.192 \times 10^{-3}$
- $0.174 \times 10^{-3}$

(78) In this circuit, the relationship between  $V_i$  &  $V_o$  is :

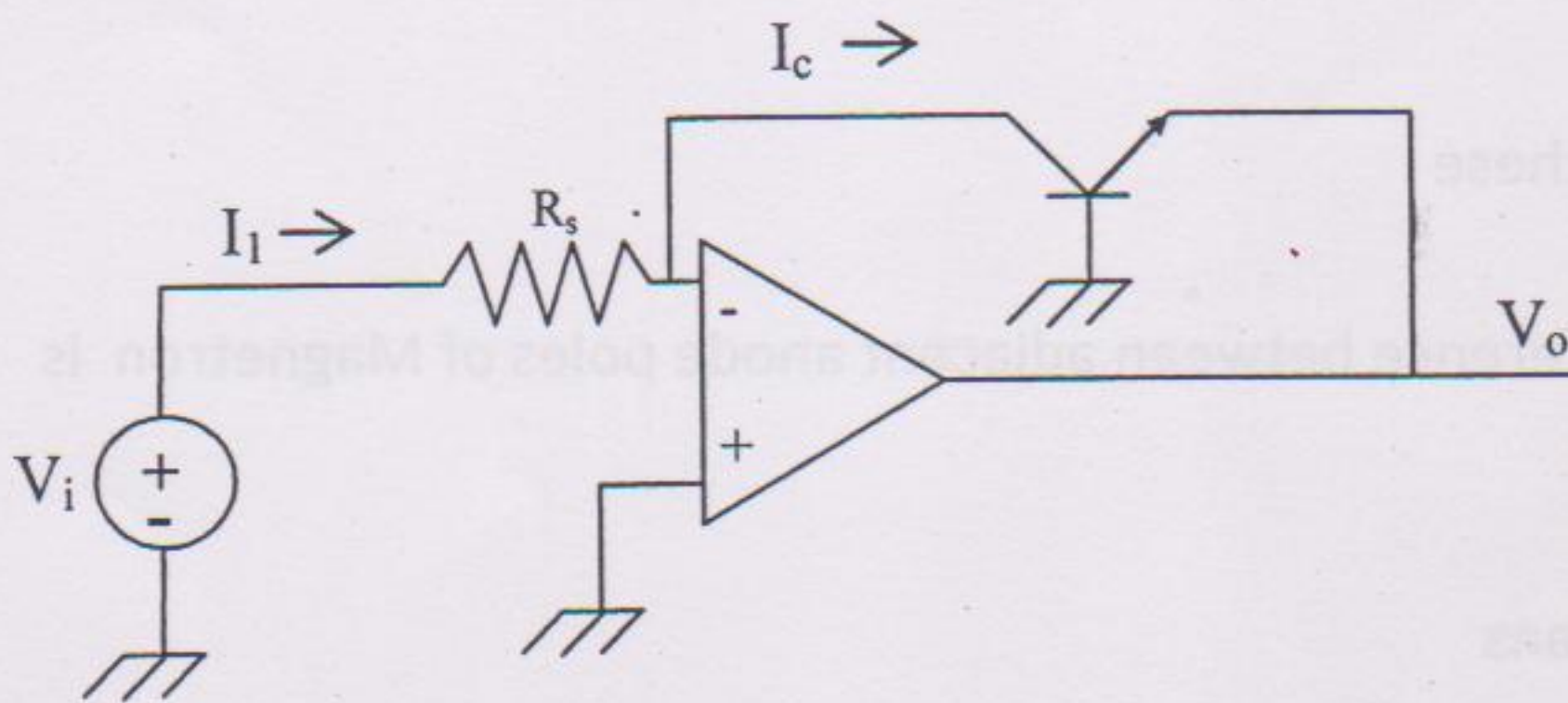

- $V_o = V_i e^{V_o/V_T}$
- $V_o = V_T \ln \frac{V_i}{R_s I_S}$
- $V_o = V_i - I_c R_s$
- None of these

(79) Output Impedance of a source follower is :

- $1/g_m + r_d$
- $r_d/(1 + g_m \cdot r_d)$
- $r_d$
- None